

TWIN TIE PLATES

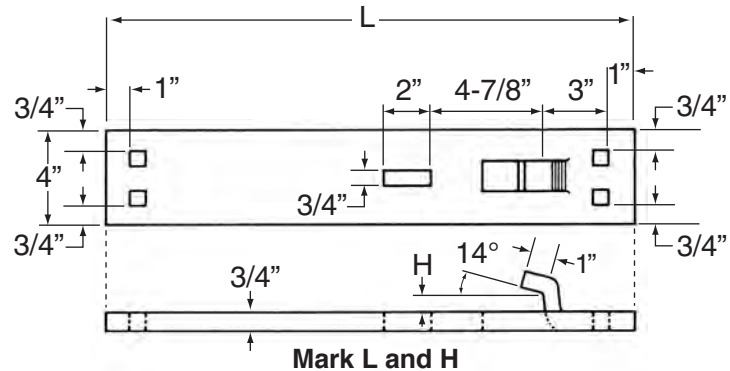

Hook Twin Tie Plates

Hook Twin Tie Plates are manufactured per AREMA plan 241. Hook twin tie plates generally come with three types of hooks: Low – Type L, Low Reverse – Type LR, and High – Type H. Type H plates do not have the slotted hole and have a higher hook designed to fit over the base of a manganese frog. If the hook of a hook twin tie plate interferes with a joint bar, the hook can be cut off or bent to a vertical position.



Hook Twin Tie Plates are manufactured per AREMA plan 241.

Mark	L	H	Wt. (lbs.)
L23	23"	9/16"	18.8
L27	27"	9/16"	22.2
L31	31"	9/16"	25.6
H23	23"	15/16"	19.1
H27	27"	15/16"	22.5
H31	31"	15/16"	25.9
LR23	23"	9/16"	18.8
LR27	27"	9/16"	22.2
LR31	31"	9/16"	25.6

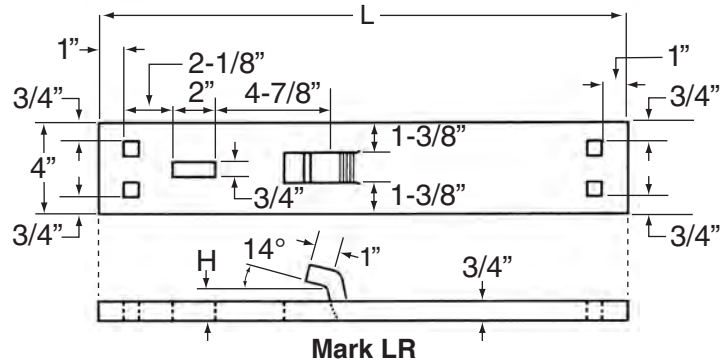

Flat Twin Tie Plates

Flat Twin Tie Plates are manufactured as shown.

Type	Weight (lbs.)	
	5/8" thick	3/4" thick
No. 1	16.9	20.3
No. 2	16.9	20.3
No. 3	20.8	24.9

