

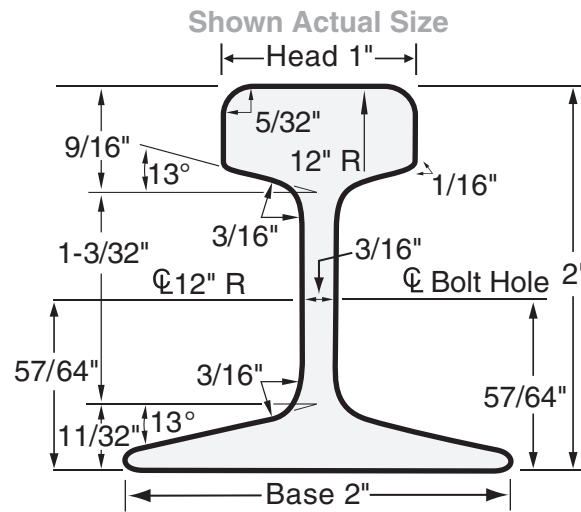

12-lb. ASCE



Rail Type:	12 AS
Section Number:	1240
Nominal Weight:	12 lbs/yd
Standard Length:	30'
Standard Drilling:	2" X 4" with 5/8" dia. holes
Splice Bar Length:	16-1/8"
Splice Bar Weight:	2 lbs/pr with hardware: 3 lbs/pr
Track Bolt:	1/2" X 1-3/4"

Area in²:	1.18
Section Modulus in³:	Head: .58
Moment of Inertia in⁴:	.55