

# 60-lb. ASCE

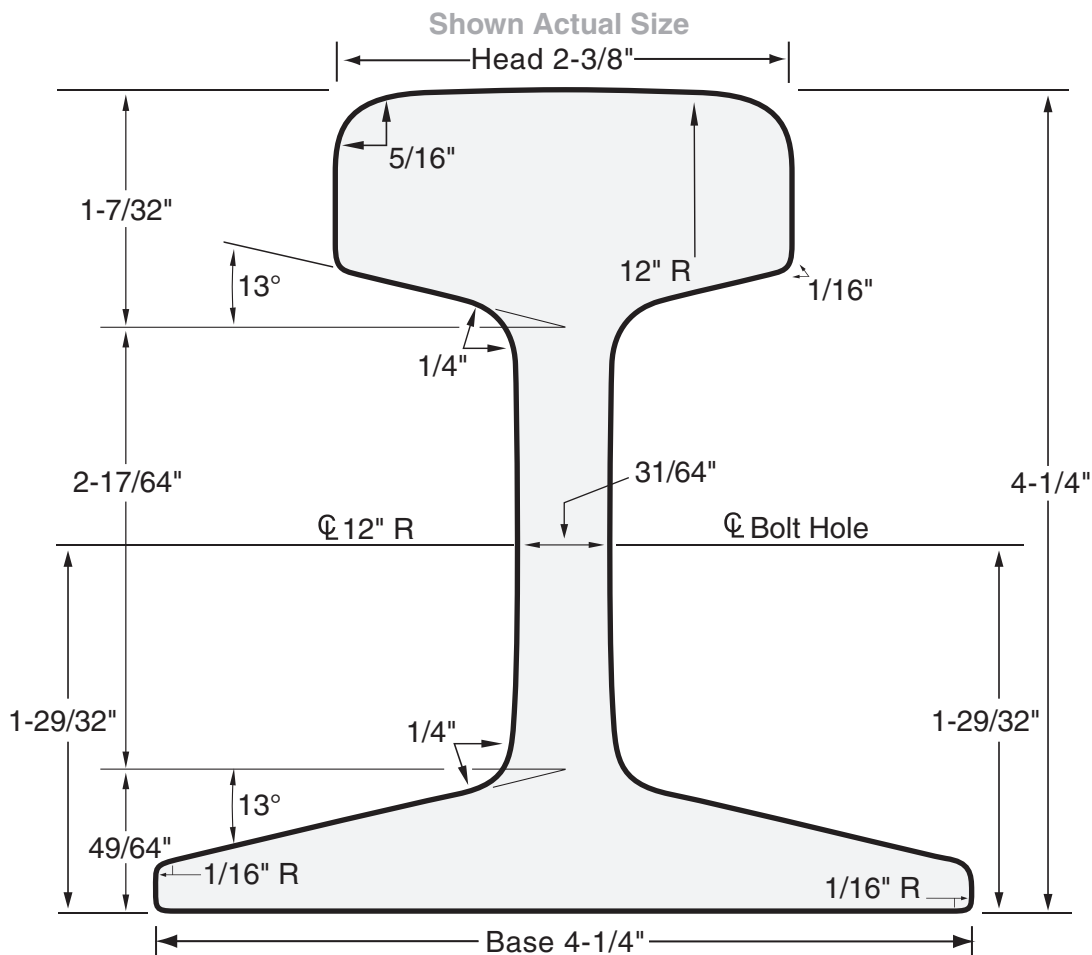

<b>Rail Type:</b>	60 AS
<b>Section Number:</b>	6040
<b>Nominal Weight:</b>	60 lbs/yd
<b>Standard Length:</b>	20', 30', 33', & 40'
<b>Standard Drilling:</b>	2-1/2" X 5" with 15/16" dia. holes
<b>Splice Bar Length:</b>	20"
<b>Splice Bar Weight:</b>	13 lbs/pr with hardware: 16 lbs/pr
<b>Track Bolt:</b>	3/4" X 4"

<b>Area in<sup>2</sup>:</b>	5.93
<b>Section Modulus in<sup>3</sup>:</b>	
<b>Head:</b>	6.62
<b>Base:</b>	7.10
<b>Moment of Inertia in<sup>4</sup>:</b>	14.56