

136-lb. AREMA

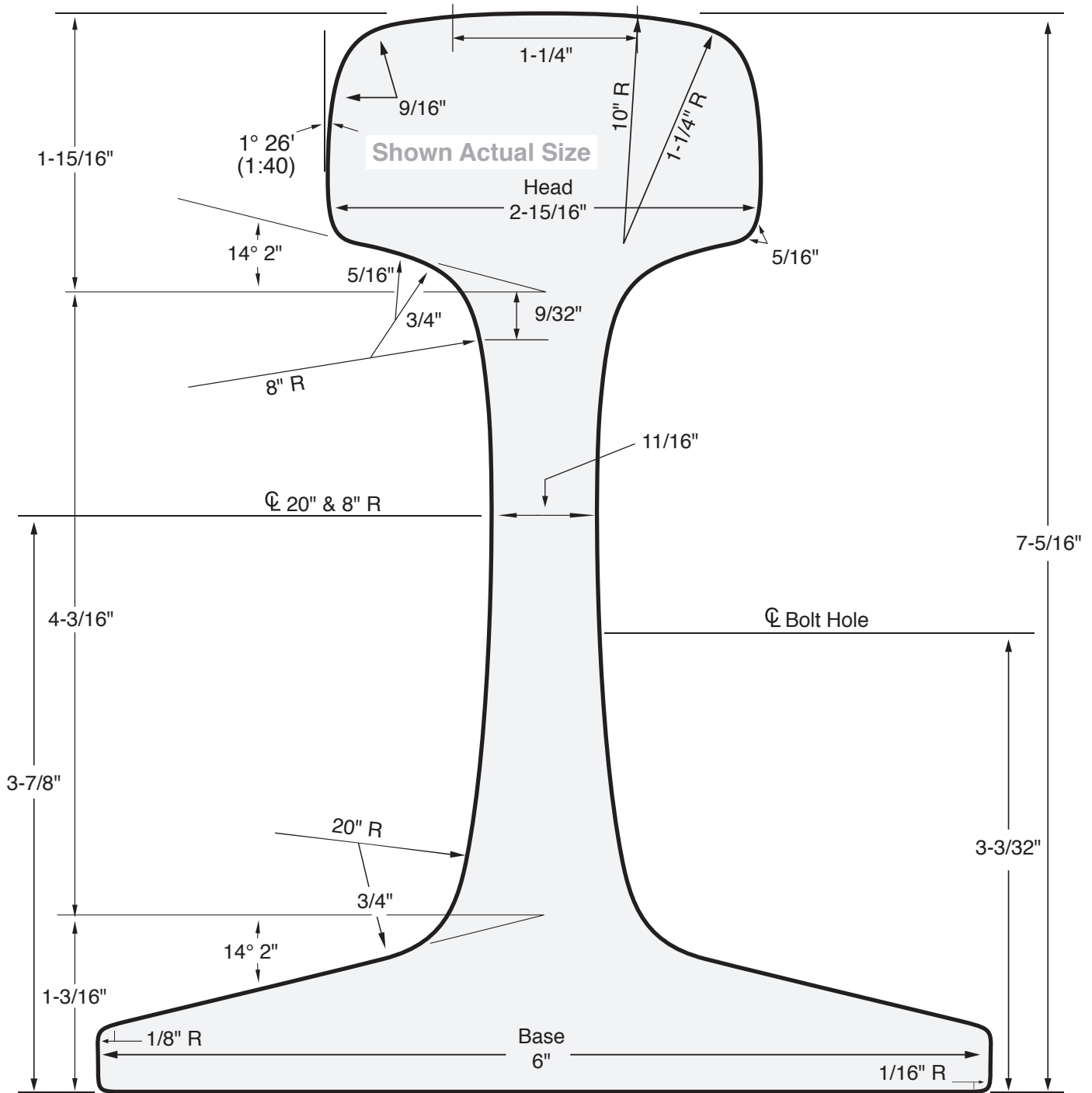

Rail Type:	136 RE
Section Number:	13625
Nominal Weight:	136 lbs/yd
Standard Length:	39', 80'
Standard Drilling:	3-1/2" X 6" or 3-1/2" X 6" X 6" with 1-1/4" dia. holes
Joint Bar Length:	24" or 36"
Joint Bar Weight:	4-Hole bars: 70 lbs/pr with hardware: 81 lbs/pr 6-Hole bars: 117 lbs/pr with hardware: 134 lbs/pr
Track Bolt:	1-1/8" X 6-1/2"

Area in²:	13.32
Section Modulus in³:	
Head:	23.78
Base:	28.3
Moment of Inertia in⁴:	93.7

BOLT SIZE MAY VARY DEPENDING ON BAR MANUFACTURE & TYPE OF WASHER USED.