

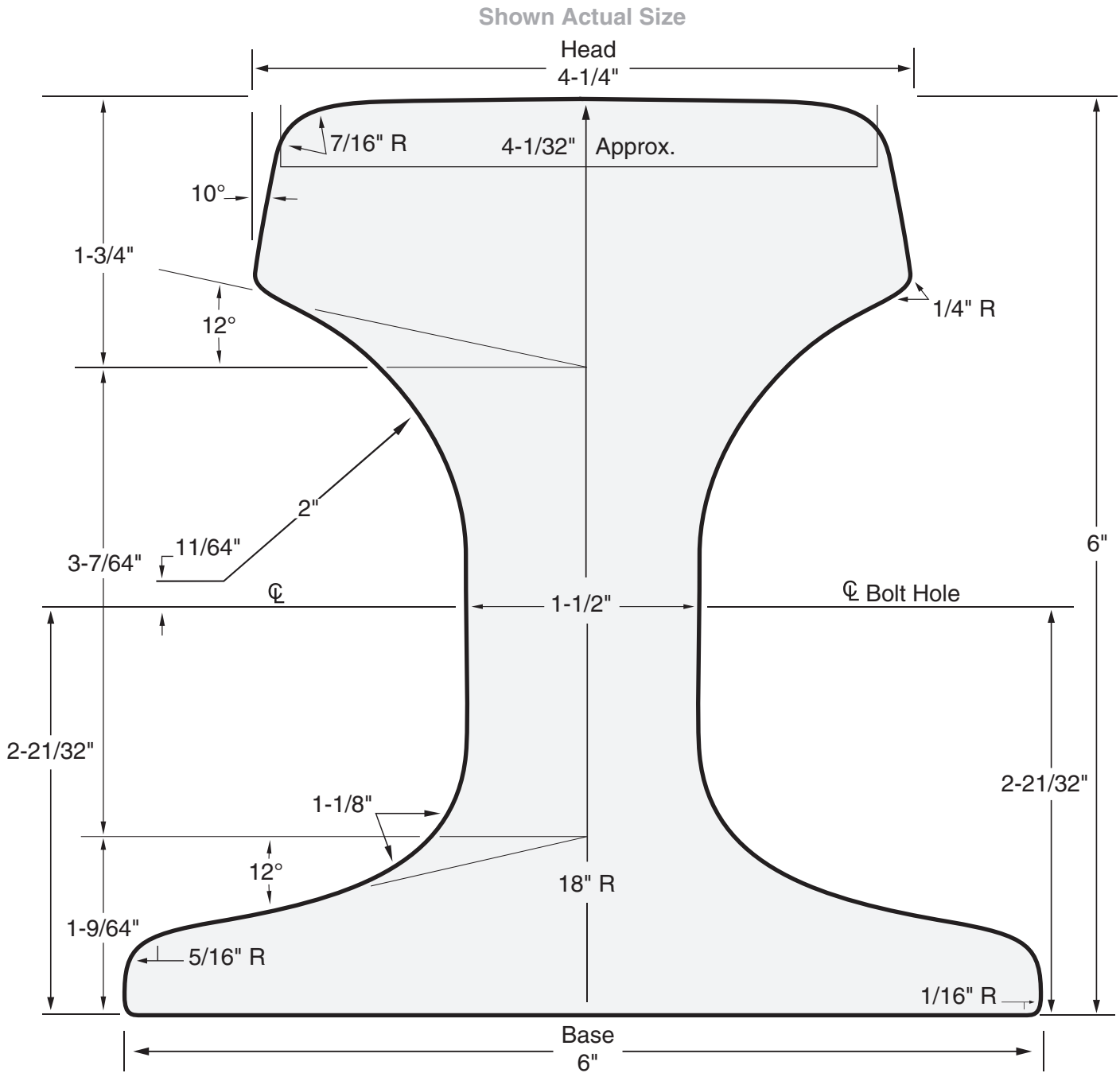

175-lb. CRANE RAIL



Rail Type:	175 CR
Nominal Weight:	175 lbs/yd
Standard Length:	39'
Standard Drilling:	4" X 5" X 6" with 1-3/16" dia. holes
Splice Bar Length:	34"
Splice Bar Weight:	72 lbs/pr with hardware: 89 lbs/pr
A325 Hex Bolt:	1-1/8" X 6-1/2"

Area in²:	17.12
Section Modulus in³:	
Head:	23.53
Base:	23.28
Moment of Inertia in⁴:	70.22