

ONE-PIECE RAIL CLIPS

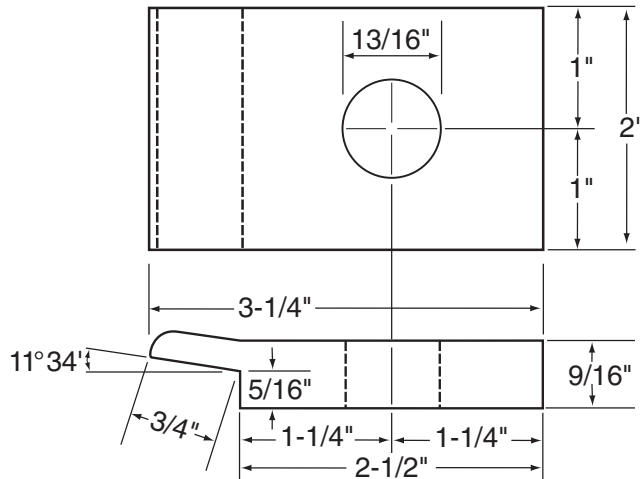

No. 120 Weight - .91 lbs.
For all sections 25 to 40 lb.

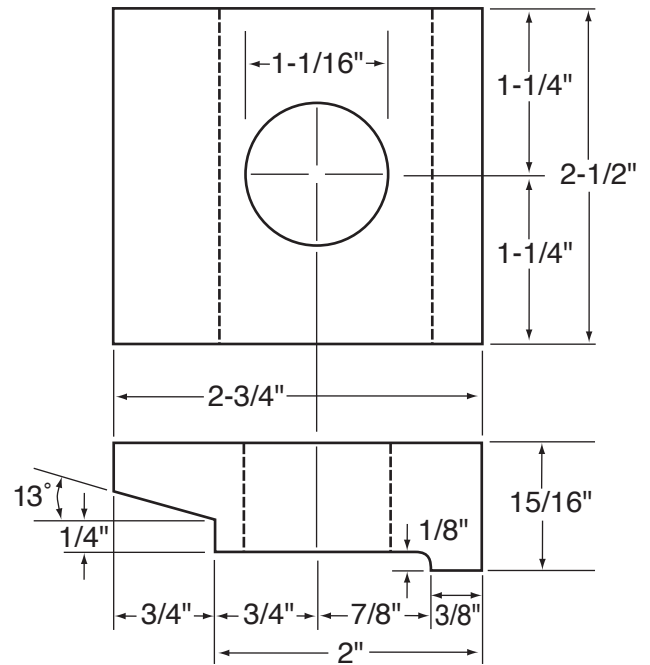

No. 62 Weight - 1.20 lbs.
For Crane rail sections 104, 105 & 135 Tee rail sections 90 - 136 lb.

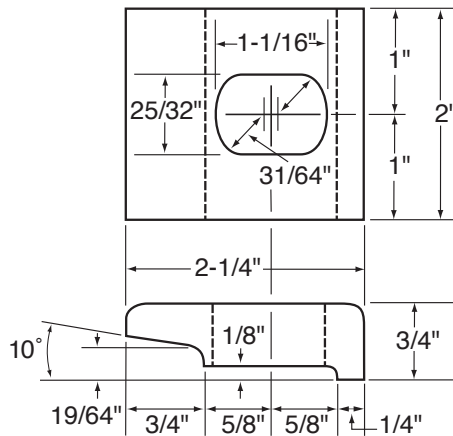

No. 103 Weight - .60 lbs.
For all sections 40 - 100 lb.

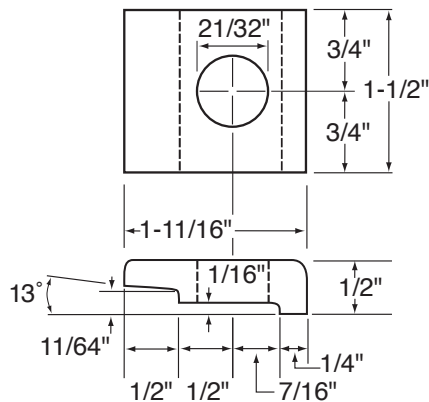

No. 114 Weight - .23 lbs.
For all section 12 to 40 lb.

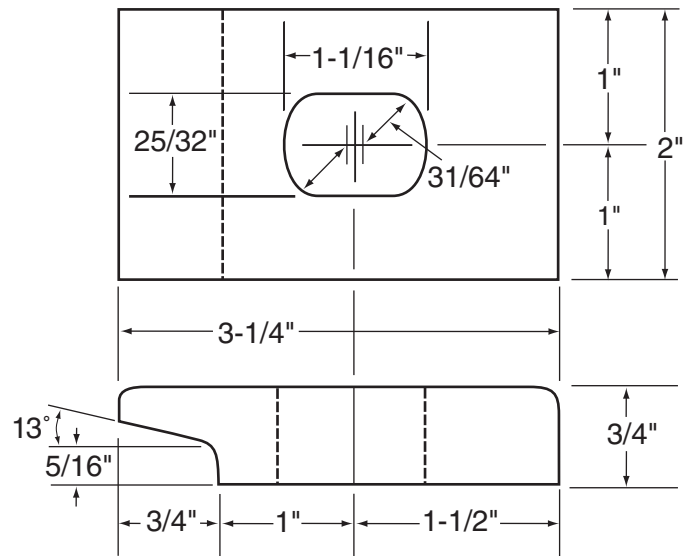

No. 106 Weight - 1.06 lbs.
For all sections 60 - 90 lb.